

Oil Flow Schematic.

For the R2800 the oil tank is 8 Litres (2.1 US Gal) in total capacity and For the R3600 the capacity is 10Litres (2.64US Gal)

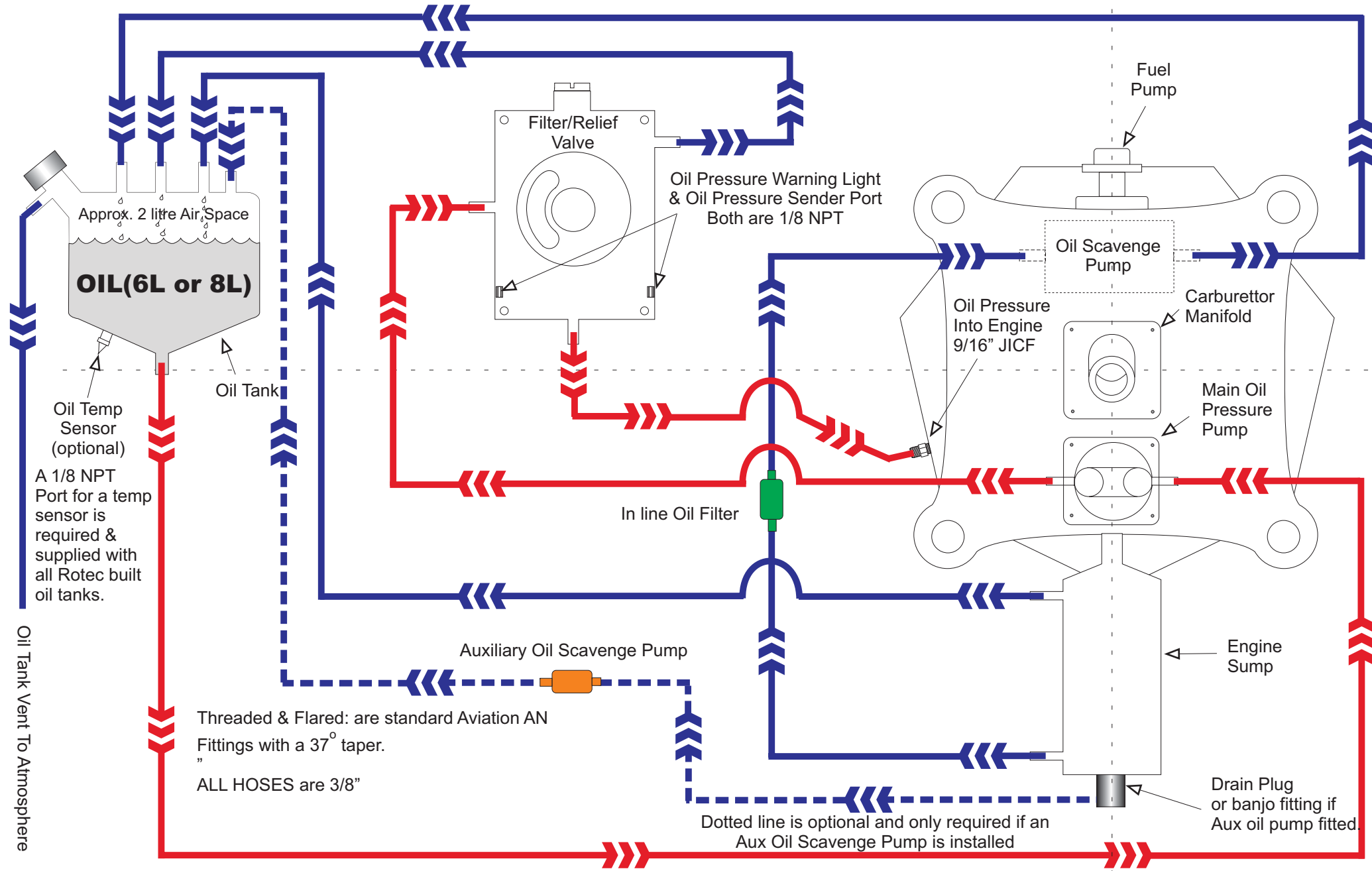

Oil Temp Sensor (optional)
A 1/8 NPT Port for a temp sensor is required & supplied with all Rotec built oil tanks.

Oil Tank Vent To Atmosphere

Threaded & Flared: are standard Aviation AN Fittings with a 37° taper.
" ALL HOSES are 3/8"

Dotted line is optional and only required if an Aux Oil Scavenge Pump is installed

Drain Plug or banjo fitting if Aux oil pump fitted.